

# IN-ADAS-Camera

## Product Specification

### Product Overview

The **IN-ADAS-CM01** is a high-performance Automotive Advanced Driver Assistance Systems (ADAS) camera module designed for vehicle safety applications. This compact and robust camera delivers 1080P high-definition video with excellent low-light performance, making it ideal for forward-facing collision warning, lane departure warning, and other driver assistance functions.

### Key Features

- Full HD 1080P Resolution
- Ultra-wide 120° horizontal field of view
- Excellent low-light sensitivity (0.1 Lux)
- Digital Wide Dynamic Range (WDR)

## Specifications

### Model Information

Parameter	Specification
Model Number	IN-ADAS-CM01
Module Type	FH8536H 1/2.9"+ GC2053
Application	Automotive ADAS (Advanced Driver Assistance Systems)

### Image Sensor & Performance

Parameter	Specification	Description
Resolution	AHD 1080P	Full High Definition 1920×1080 pixels
Video System	PAL	Phase Alternating Line standard
Total Pixels	1920(H) × 1080(V)	2.1 Megapixels effective resolution
Minimum Illumination	0.1 Lux	Excellent low-light sensitivity for night driving scenarios
Electronic Shutter	PAL: 1/50 ~ 1/100,000s	Auto-adjusting shutter speed for varying lighting conditions
Signal-to-Noise Ratio (S/N)	> 52dB	High-quality image with minimal noise
White Balance	Auto White Balance (AWB)	Automatic color temperature adjustment
Day/Night Mode	Color Mode	Optimized for daytime and well-lit conditions
Digital WDR	Enabled	Wide Dynamic Range for high-contrast scenes
Mirror Function	Disabled	Standard non-mirrored output
UTC Function	Enabled	Up-the-coax control for remote configuration

## User Interface

Parameter	Specification
OSD Language	English (Default)
Video Output	1.0Vp-p Composite Video, 75Ω

## Lens Specifications

Parameter	Specification	Description
Focal Length	2.1mm	Wide-angle lens configuration
IR Filter	650nm Bandpass Filter	Optimized for visible light spectrum
Field of View (FOV)	Horizontal: 120°	Ultra-wide angle for maximum coverage

## Electrical Specifications

Parameter	Specification	Description
Power Supply	DC 12V ±10%	Standard automotive voltage input
Power Consumption	Refer to module datasheet	Low power design for vehicle integration

## Environmental Specifications

Parameter	Specification	Description
Operating Temperature	-20°C ~ +70°C (-4°F ~ +158°F)	Designed for harsh automotive environments
Operating Humidity	< 90% RH (Non-condensing)	Protected against humidity
Storage Temperature	-40°C ~ +80°C	Safe storage temperature range

## Mechanical Specifications

Parameter	Specification	Description
Connector Type	GX12 4-Pin Female	Industry-standard M12 locking connector for vibration resistance
Cable Length	1900 mm	Flexible cable length for easy installation
Dimensions	See dimension drawing	Compact form factor for easy integration
Mounting	3M adhesive attached to glass	

## Package Contents

Item	Quantity
Camera Module	1pc

## Product Images

### Camera Module Overview



### Connector Pin Definition

GX12 4-Pin Circular Aviation Connector, Female Receptacle (Socket) Connector Pinout:

Pin 1: +12V DC Power Input

Pin 2: DC Ground (GND)

Pin 3: NONE

Pin 4: Video Output (AHD)

Note: Refer to actual product documentation for exact pin configuration

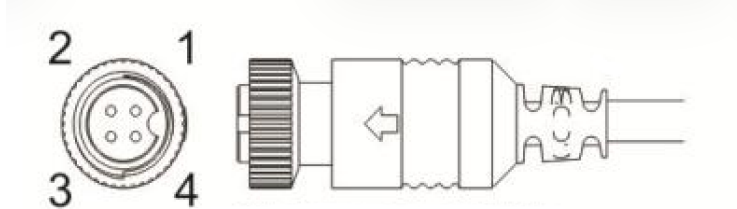

## Dimensions (mm)

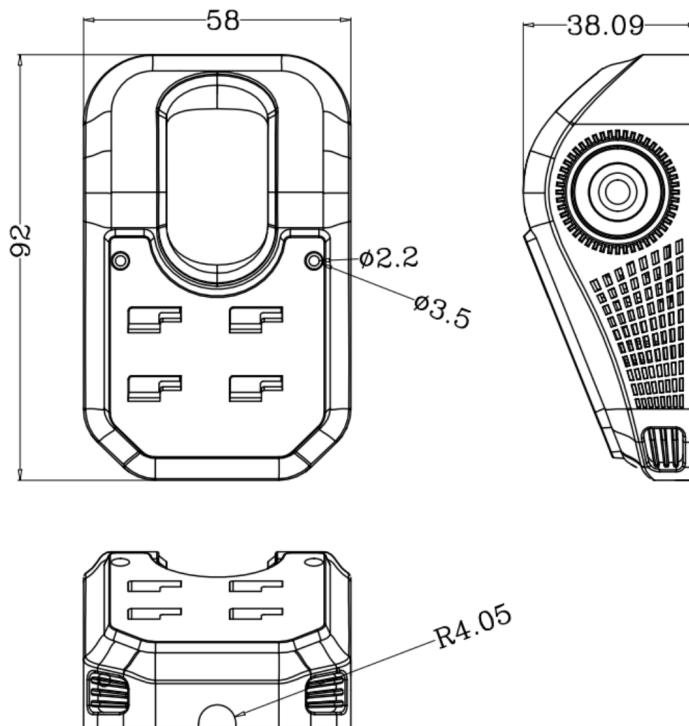

## Application Scenarios

This ADAS camera module is suitable for:

- **Forward Collision Warning (FCW):** Detects vehicles and obstacles ahead
- **Lane Departure Warning (LDW):** Monitors lane markings
- **Traffic Sign Recognition (TSR):** Identifies road signs and traffic signals
- **Pedestrian Detection:** Recognizes pedestrians in the vehicle path
- **Vehicle Recording:** Event and continuous video recording
- **Fleet Management:** Commercial vehicle monitoring systems

# Technical Highlights

---

## AHD Technology

This camera utilizes **AHD (Analog High Definition)** technology, which provides:

- 1080P HD video transmission over standard coaxial cable
- Longer transmission distances compared to digital solutions
- Cost-effective installation with existing cabling infrastructure
- Low latency for real-time applications

## Digital WDR

**Wide Dynamic Range** technology enables the camera to:

- Capture clear images in high-contrast lighting conditions
- Balance bright and dark areas in the same scene
- Provide visibility when entering/exiting tunnels or parking structures
- Maintain detail in both shadows and highlights

## 0.1 Lux Low-Light Performance

The camera's high sensitivity allows for:

- Clear image quality in dusk and dawn conditions
- Improved performance in street lighting scenarios
- Enhanced detection capabilities during nighttime driving (with adequate ambient lighting)

---

## Compliance & Certifications

Note: Please refer to actual product certifications for specific compliance information:

- Automotive electronic compatibility standards
- Environmental protection ratings
- Quality management system certification

---

## Ordering Information

**Product Code:** IN-ADAS-CM01

For technical support, pricing, and bulk orders, please contact the manufacturer or authorized distributor.

---

## Revision History

Version	Date	Description
1.0	October 10, 2025	Initial Release

---

**Document prepared by:** InHand Mobility Team