



Embrace the Digital & Intelligent Future

InCAM201

Camera for Merchandiser

InCAM201 is a snap-shot machine designed for product recognition on regular display freezers, and it has a rectangular shape.

This product is optimized for selling environments such as regular retail and supermarket shelves, with greatly improved image quality and physical mechanics, which can satisfy the requirements of static product recognition, display recognition, and product recognition with image AI algorithms in retail scenarios.

The product features excellent image quality, optimized coding and transmission, quick integration with universal protocols, flexible structural design, and high reliability. It can effectively empower the AIOT capability of traditional freezers and retail shelves, enabling brand owners to accurately grasp offline sales data, provide operational efficiency, and standardize display, efficient management, and reduce costs while increasing efficiency.

- Fast adaptive to changes in light, with high clarity, low noise, and stable images
- Uses a 160° full glass lens with 2 million high-definition pixels
- Adopting high-definition sensors and deeply optimized ISP algorithms for retail freezer scenarios

Features and Advantages

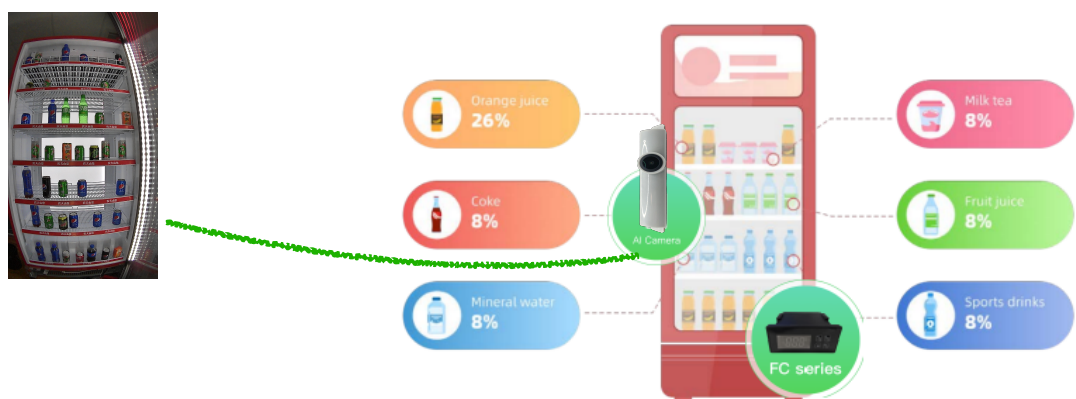

Dimensions (mm)

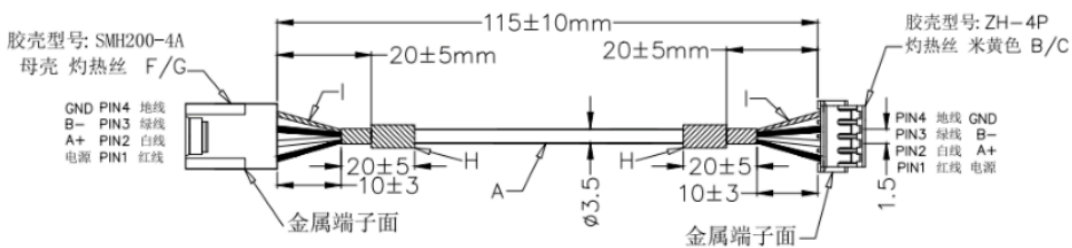
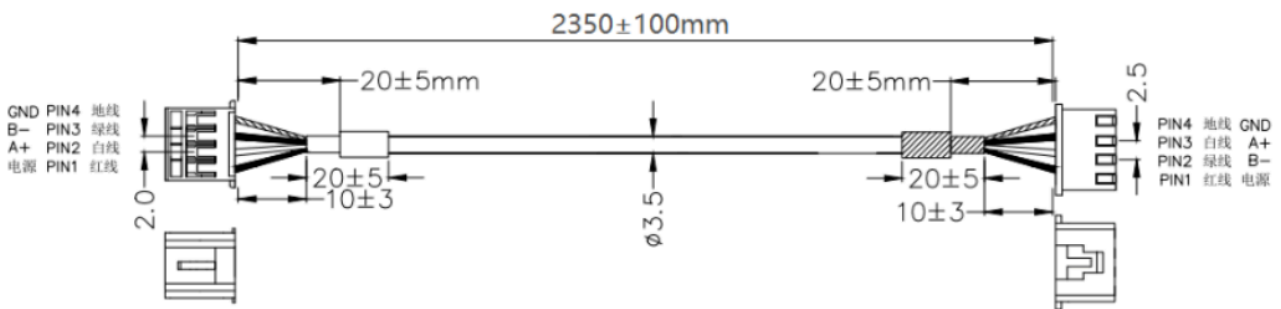
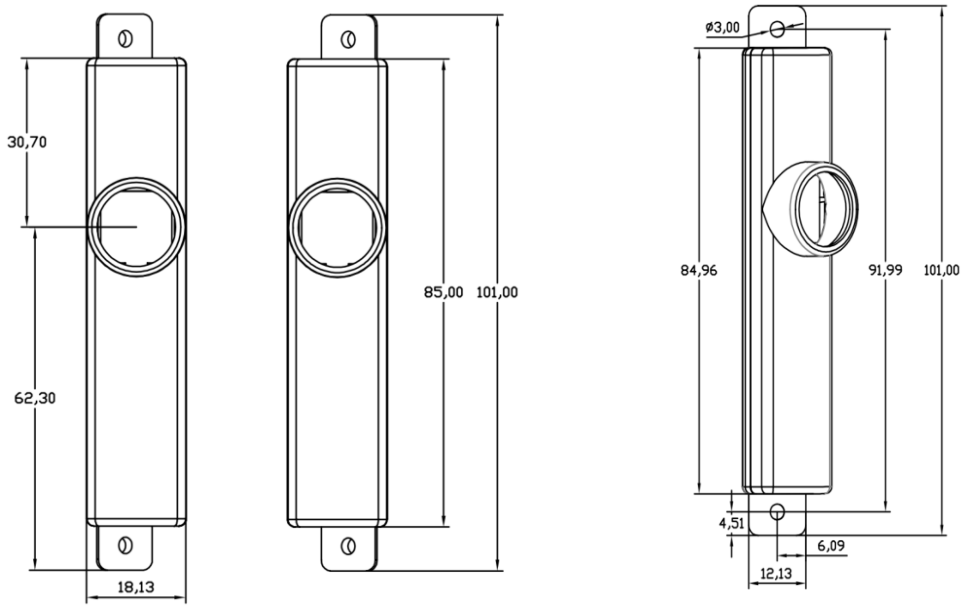
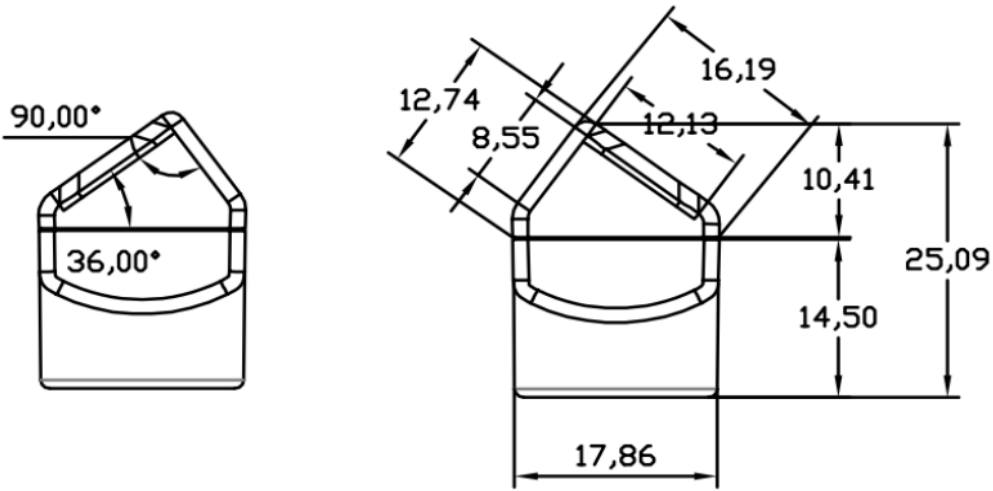

Product Specifications

Lens	Construction	2G+3P
	Aperture D/f	F2.8
	Focal-Length	2.18mm±5%
	Back Focal-Length	2.7mm±5%
	FOV	D: 166°diagonal, H: 140°horizontal, V: 78°vertical.
Image Parameters	Sensor	1/2.9", CMOS
	Array Size	1920(H) x 1080(V)
	Low illumination	support
	Wide dynamic	support
	Encoding format	MJPEG
	Image resolution	1080P/720P/360P
Other features	Demist	support
	Motion sensor	Support to take a picture when opening freezer door
General parameters	Machine Size	102*19*25mm
	Waterproof level	IPX6
	Temperature	-15°C to 50°C
	Storage temperature	-30°C to 70°C
	Humidity	≤95%RH

Ordering Guide

Model	Model code: InCAM<BB><C><DD>-<FF>-<ZZ>				
InCam201-GB	Global	RS485	60° full glass lens with 2 million high-definition pixels	FC	<NA>

About Us

InHand Networks is a global leader of Industrial IoT, with a record of tremendous success following groundbreaking innovation since our inception in 2001.

InHand serves world-class partners and customers with industrial M2M routers, gateways, industrial Ethernet switches, rugged computers and IoT management platforms. We provide IoT solutions for various vertical markets including Smart Grid, Industrial Automation, Remote Machine Monitoring, Smart Vending, Smart City, Retail and more.

Proudly bearing the marks of both Rockwell Automation Technology Partner in Asia-Pacific and Schneider Electric Technology Partner, InHand Networks defines industrial innovation and reliability.



43671 Trade Center Place, Suite 100, Dulles, VA 20166 USA
 T: +1 (703) 348-2988
 E: info@inhandnetworks.com
 www.inhandnetworks.com