



InHand Networks



All in one, High-performance, Hardened

InVehicle Gateway 814 Series

Cellular Gateway for Information Technology for Public Transport (ITxPT)

The InVehicle G814 cellular gateway provides high-speed and secure network access for public transportation, including metro, light rail and train.

Its all in one design integrates 5G or LTE Advanced high-speed Wi-Fi, Gigabit Ethernet and CANBus to provide fast, reliable and secure network access for in-vehicle networking and Internet connectivity.

The gateway is embedded with powerful edge computing capability and supports fast custom application development by using Python or Docker. It also supports Microsoft Azure and AWS IoT cloud platform integration.

The TNC RF connectors and M12 connectors are specially designed for rail environment.

Applications

- Public Transport ITS
- Internet of Vehicles
- Passenger Wi-Fi
- Passenger Infotainment

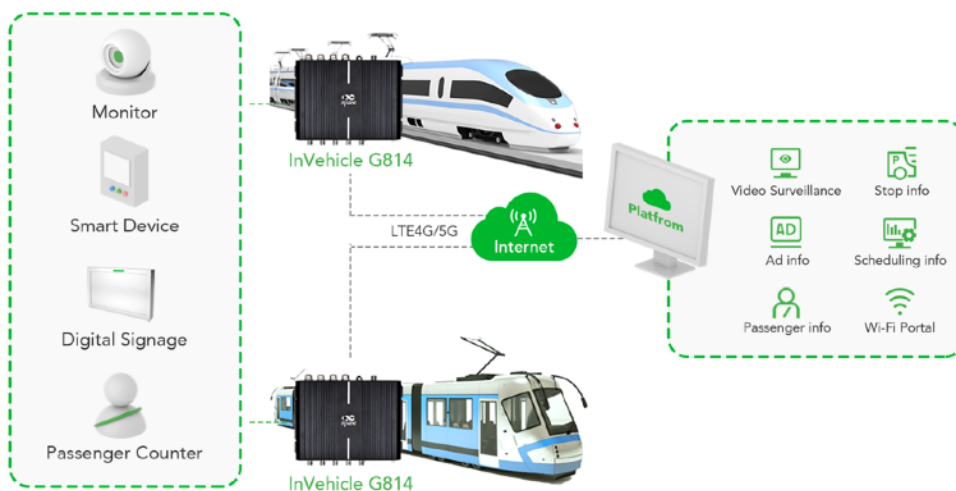

Features and Advantages

- + Supports 5G or LTE-A
- + Built-in link redundancy, dual SIM, link backup
- + Dual-band Gigabit Wi-Fi and High Speed Ethernet
- + M12-X and TNC connectors for rail transit
- + Easy to manage and deploy in large scale
- + OTA upgrade service
- + Integrated OBD-II/J1939/diagnostic interface
- + Industrial-grade chip, communication module and electronic components
- + Support C/C++ Python and Docker for secondary development
- **Robust network access capability**
Supports 5G download speed up to 5 Gbps NSA, 4.2 Gbps SA and upload speed up to 450 Mbps, backward compatible with 4G/3G.
- **Designed for railway**
Designed for challenging operating environments in railway. Industrial-grade processor chip ensures continuous operation on-board vehicles. Meet the railway standards EN50155 and EN45545
- **Global satellite positioning**
72-channel high-precision high-sensitivity global satellite positioning system. Update location information 10 times in 1 second, tracks vehicle locations precisely at any time anywhere.
- **Vehicle diagnostics collection**
Integrates multiple interfaces including OBD-II and J1939 to collect vehicles diagnostics, and API interface to upload the data to the application platform in real time.
- **All in one design multi business involved**
4 Gigabit Ethernet interfaces to provide high-speed traffic link for vehicle area network. Integrates multiple channels of I/O inputs, outputs, and analog inputs, RS232/RS485 serial port connect more devices.
- **Edge computing**
Outstanding edge computing capabilities extend analytical calculation to the network edge within the vehicle, improving the efficiency of data processing, which meets the basic need for real-time business and application intelligence in the Internet of Vehicles (IoV) industry.
- **Fleet management platform**
Supports access to InHand or a 3rd-party fleet management platform to perform: task assignment, route planning, vehicle tracking, real-time messaging, geofencing, etc. Supports network management, reducing the complexity of device management and service deployment.
- **Developer features**
The comprehensive secondary development platform opens key system resources to users, facilitating fast development and deployment of custom applications. Integrating cloud-end IoT SDK, enables quick building of AWS, Azure and other mainstream clouds based applications.
- **Support InHand Device Manager**
Device Manager platform enables you to manage and monitor VG814 devices with convenience. It can quickly integrate devices and manage them with just a few clicks. The cloud deployment delivers easy-to-use experience.

InVehicle G814 Hardware Specifications			
Core			
CPU	ARM Cortex A7 (quad-core)	Frequency	717MHz
RAM	1GB DDR3L	FLASH	8GB eMMC
WWAN			
Cellular	5G SA/NSA Sub6 4G LTE CAT6/CAT4	SIM	2 x Mini SIM 2FF
MIMO	5G :4x4 4G : 2x2	Antenna Connector	TNC
GNSS			
GNSS Receiver	GPS, GLONASS, Galileo, Beidou	Antenna Connector	TNC
Dead Reckoning	Supported with builtin sensors (accelerometer and gyroscope)		
Accuracy	2.5m CEP、 Support ADR		
Sensitivity	-160dBm	Location Update Rate	MAX 10Hz
ADR	2 % of distance travelled without GNSS		
Wi-Fi			
Frequency	2.4G / 5GHz Dual-band	Protocol	Wi-Fi 5
Maximum Output	2.4G: 17dBm 5G: 17dBm 1200Mbps	Working Mode	AP / Client
MIMO	2 x 2 Mu-MIMO	Antenna Connector	TNC
Ethernet			
Ports	4 x Gigabit Ethernet	Connector	M12 X-Coded female
Serial port, USB, IO			
Serial port	2xRS232 1xRS485		
Standard	1 x USB 3.0	Connector	USB Type A
DI	11 x digital input	DO	4 x digital output
Additional Interfaces			
CANBus	1 x CAN 2.0B	CANBus FMS	1 x CAN 2.0B M12 A-coded female
LED			
Indicator	System, Cellular, Signal, GNSS, Wi-Fi 2.4G, Wi-Fi 5G		
Power Supply			
Power Connector	M12 A-Coded male		
Pin Definition	V+, V-, Ignition, NC (4 pins)		
Input Voltage	9-36VDC		
Standby Power	0.006W - monitors ignition signal only; system starts on ignition		
Operating Power	16.00W - average when RF module running at full load		
Peak Power	20.0W - peak value when RF module running at full load		
Mechanical			
Mounting	Wall mounting	Ingress Protection	IP53
Cooling	Fanless cooling	Enclosure	Aluminum
Dimensions (W x H x D)	223 x 178 x 66.2 mm	Weight	1438 g
Environmental			
Operating Temperature	-30 °C ~ +70 °C	Storage Temperature	-40 °C ~ +85 °C
Humidity	95% RH @ 40°C	Start-up	-35 °C
Compliance			
Rail Standard	EN50155, EN50121-3-2 EN61373, EN45545-2		
Certification	CE, RoHS, E-Mark		

InVehicle G814 Software Specifications			
Network Connection			
Network Access	APN, VPDN	LAN Protocol	ARP, Ethernet
Access Authentication	CHAP/PAP/MS-CHAP/MS-CHAP V2	VLAN	VIDs: 1-127
Network Protocols			
IP Application	Ping, Traceroute, DHCP server/relay/client, DNS relay, DDNS, Telnet, SSH, HTTP, HTTPS, MQTT		
IP Routing	Static routing, RIP, OSPF, BGP		
Network Security			
Firewall	SPI, DoS attack defense, multicast/Ping probe filter, ACLs Supports NAT, NAPT, DMZ, port mapping		
User Level	2 levels: administrator; read-only user		
AAA	Local authentication, Radius, TACACS+, LDAP		
Certificate	PEM, PKCS12, SCEP, CRL		
VPN	IPsec VPN, OpenVPN, L2TP, GRE		
ITxPT			
Services	Inventory, Time, GNSS, FMStoIP, MQTT broker		
Reliability			
Redundancy	Floating Static Routes, VRRP, interface backup		
Link Detection	Configurable target reachability detection to aid failover		
Watchdog	Auto recovery from device faults		
Offline Storage	Records key data to built-in storage when network is unavailable		
WLAN			
Protocol	IEEE802.11 a/b/g/n/ac		
Security	Shared key, WPA/WPA2 Personal/Enterprise authentication WEP/TKIP/AES encryption		
Other	Multiple SSIDs, Captive Portal		
Network Management			
Configuration	HTTP, HTTPS, Telnet, SSH		
Upgrade	WebUI, Device Manager		
Diagnostic	ping, traceroute, tcpdump, speed test		
Edge Computing Framework			
Computing Platform	Integrates network, computing, storage, runtime and application hosting		
Programmable	C/C++, Python and Docker		
SDK	Python 3 SDK, Docker SDK and Azure IoT Edge SDK		
IDE	Visual Studio Code for APP development and debugging		
API	FlexAPI over MQTT/HTTP/TCP		
Cloud Integration	Microsoft Azure, AWS IoT and other third-party platforms supported		
Applications			
Fleet Management	All in one design yet programmable with open interfaces. It's one stop hardware & software solution for your Fleet Management		
Vehicle Telematics	Rich interfaces and data such as GNSS, OBD-II, J1939, Modbus, IO for vehicle telematics and asset tracking		
Passenger Wi-Fi & Infotainment	Increase passenger satisfaction by high speed and stable Internet connectivity for content delivery, along with seamless Wi-Fi experience		
Public Transport ITS	Ensure passenger and driver safety, improve operational efficiency and emission reduction to form a green, safe and sustainable society		

Connector Pin Assignment

PWR	PIN	Signal
	1	VIN+
	2	IGT
	3	VIN-
	4	NC

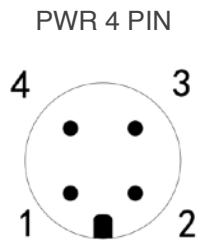

FMS	PIN	Signal
	1	CAN1_H
	2	CAN1_L
	3	GND
	4	NC

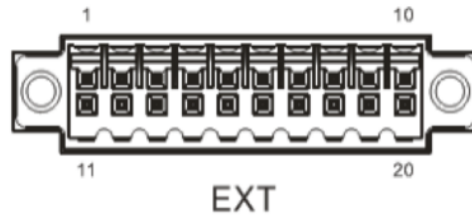
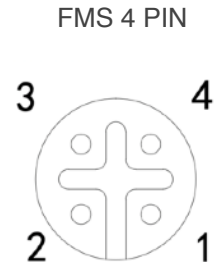

PIN	1	2	3	4	5	6	7	8	9	10
Signal	GND	DO2	DO4	WHEEL TICK*	GND	RS232_RX1	RS232_RX2	GND	CAN0_L	RS485_A
PIN	11	12	13	14	15	16	17	18	19	20
Signal	GND	DO3	PPS	FWD*	GND	RS232_TX1	RS232_TX2	GND	CAN0_H	RS485_B

* WHEEL TICK and FWD is ADR function reserve PIN, VG814-NRQ3-W-Ga-V is supported.

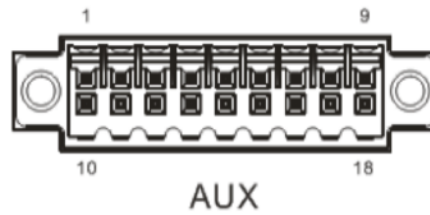

PIN	1	2	3	4	5	6	7	8	9
Signal	DI1	DI2	DI3	DI4	DI5	DI6	DI7	DI8	GND
PIN	10	11	12	13	14	15	16	17	18
Signal	GND	GND	GND	GND	DI9	DO1	DI10	DI11	GND

Dimensions (mm)

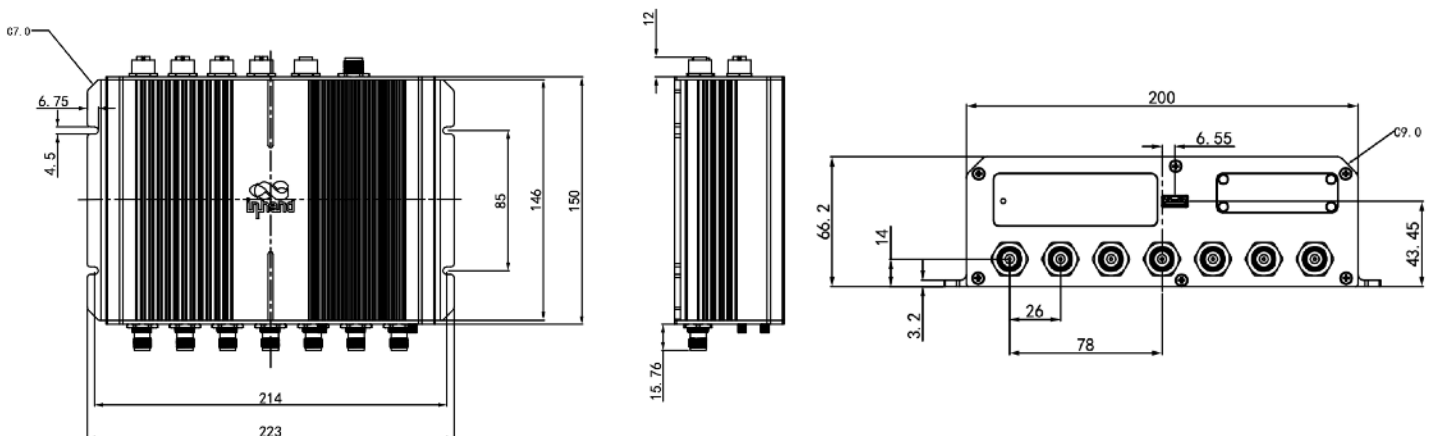

Ordering Guide

Model	Cellular Type	UE Category	CAN BUS	GNSS	Wi-Fi	Antenna Connector	Region
VG814-FS59-W-G-R	LTE-FDD B1/B3/B5/B7/B8/B18/B19/B20/B26/B28A/B28B LTE-TDD B38/B39/B40/B41 TD-SCDMA B39/ B34 UMTS/HSPA+ B1/B3/B5/B6/B8 GSM/GPRS/EDGE: 900/1800MHz	LTE Cat 6	2	✓	✓	TNC	Europe Africa APAC Oceania
VG814-FQ59-W-G-R	LTE-FDD B1/B3/B5/B7/B8/B20/B28/B32 LTE-TDD B38/B40/B41 WCDMA B1/B3/B5/B8	LTE Cat 6	2	✓	✓	TNC	Europe APAC
VG814-NRQ3-W-G-R	5G NR NSA: n1/n2/n3/n5/n7/n8/n12/n20/n25/n28/n38 /n40/n41/n48*/n66/n71/n77/n78/n79 5G NR SA: n1/n2/n3/n5/n7/n8/n12/n20/n25/n28/n38 /n40/n41/n48*/n66/n71/n77/n78/n79 LTE-FDD:B1/B2/B3/B4/B5/B7/B8/B9/B12(B17)/B13/B14/B18 /B19/B20/B25/B26/B28/B29/B30/B32/B66/B71 LTE-TDD:B34/B38/B39/B40/B41/B42/B43/B48 LTE Category: DL CAT20/UL CAT18 LAA:B46 WCDMA Bands:B1/B2/B3/B4/B5/B6/B8/B19	5G Sub6	2	✓	✓	TNC	Global
Example:	VG814-FS59-W-R contain Wi-Fi 5, 4GE-M12, FMS, 2 x RS232, 1 x RS485, 4 x DO 1 x CAN2.0B 11*DI, TNC Antenna Connector.						

About Us

InHand Networks is a global leader of Industrial IoT, with a record of tremendous success following groundbreaking innovation since our inception in 2001.

InHand serves world-class partners and customers with industrial M2M routers, gateways, industrial Ethernet switches, rugged computers and IoT management platforms. We provide IoT solutions for various vertical markets including Smart Grid, Industrial Automation, Remote Machine Monitoring, Smart Vending, Smart City, Retail and more.

Proudly bearing the marks of both Rockwell Automation Encompass Product Partner in Asia-Pacific and Schneider Electric CAPP Technology Partner, InHand Networks defines industrial innovation and reliability.



43671 Trade Center Place, Suite 100, Dulles,
VA 20166, USA

T: +1 (703) 348-2988

E: info@inhandnetworks.com

www.inhandnetworks.com

