

Build advanced and highly reliable industrial Ethernet communication system

ISM5020D-P

Managed Industrial Ethernet Switch

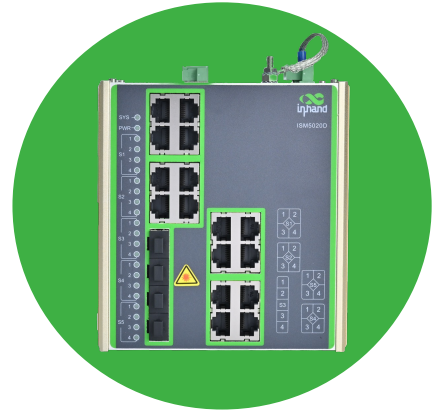

The ISM series Managed Industrial Ethernet Switch has been purpose-built to cater to the rigorous demands of industrial settings, including power, transportation, and industrial control applications. Featuring a rugged enclosure and safeguarded circuits, this series boasts industrial-grade characteristics, ensuring outstanding adaptability. It excels in reliably operating under extreme temperature conditions, efficiently tackling the challenges presented by harsh environmental factors.

Moreover, the ISM5020D is equipped with advanced and comprehensive network functionalities, supporting RSTP/MSTP/ERPS/MRP ring redundancy protocols. This provides users with flexible options for building complex industrial Ethernet communication systems. Whether facing adverse production environments or industrial applications with strict requirements for reliability and availability, InHand Networks' Industrial Ethernet Switch can meet your expectations.

Solutions

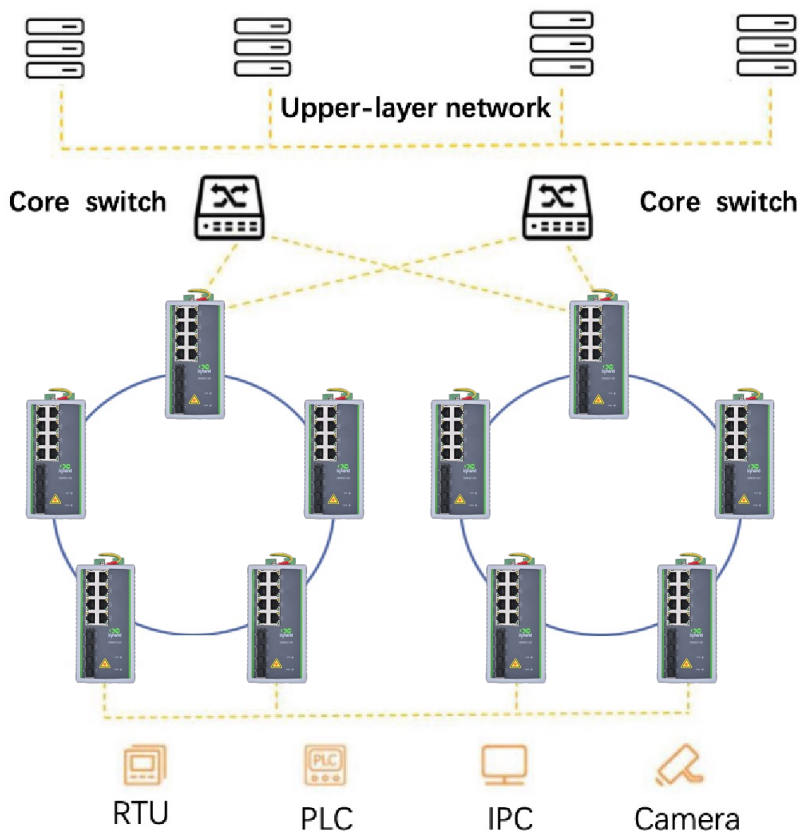

Advantages and Features

- + Excellent EMC electromagnetic compatibility and radiation performance
- + Support ERPS/MRP Ring Protocol recovery time $\leq 50\text{ms}$
- + Support overvoltage protection
- + Support for Dynamic ARP Inspection or Dynamic ARP Protection, DHCP Snooping, Management ACL, L2/L3/L4 Access Control Lists, and IP Source Guard
- + Support WEB/CLI reset factory setting, auto-reset script program
- + Support Dying gasp function and initiatively report power-down state through SNMP protocol
- + Support ToS Classification and Re-marking & DSCP
- + Support SNMP Trap
- + Support sFlow Protocol
- + Support Static routing

• Build advanced and highly reliable industrial Ethernet communication

ISM Managed Industrial Switch features a rugged metal casing and protective coating, providing pressure resistance and corrosion protection.

The product is fanless, with IP40 protection, dust and dirt resistance, and supports wide temperature operation.

Industrial-grade redundant power supply design, wide voltage input, ensuring stable communication in harsh industrial environments. The product's MTBF (Mean Time Between Failures) is over 35 years.

• Efficient and effortless deployment and management

The ISM series supports SNMP, enabling the display of all port statuses, VLAN information, connected users, and MAC address information for devices of different brands. Additionally, it provides graphical representation of traffic through interfaces, monitoring of device temperature and processor usage, as well as information about neighboring devices.

Supports RMON, SNMP v2c/v3, enabling comprehensive and effective network monitoring and fault prediction, allowing users to deploy and manage networks quickly and efficiently; DIN rail mounting, compact size, plug-and-play for swift deployment.

• Robust network security performance

IGMP Snooping.

Intelligent features such as VLAN network segmentation.

Product dimensions(mm)

ISM5020D Dimensional diagram

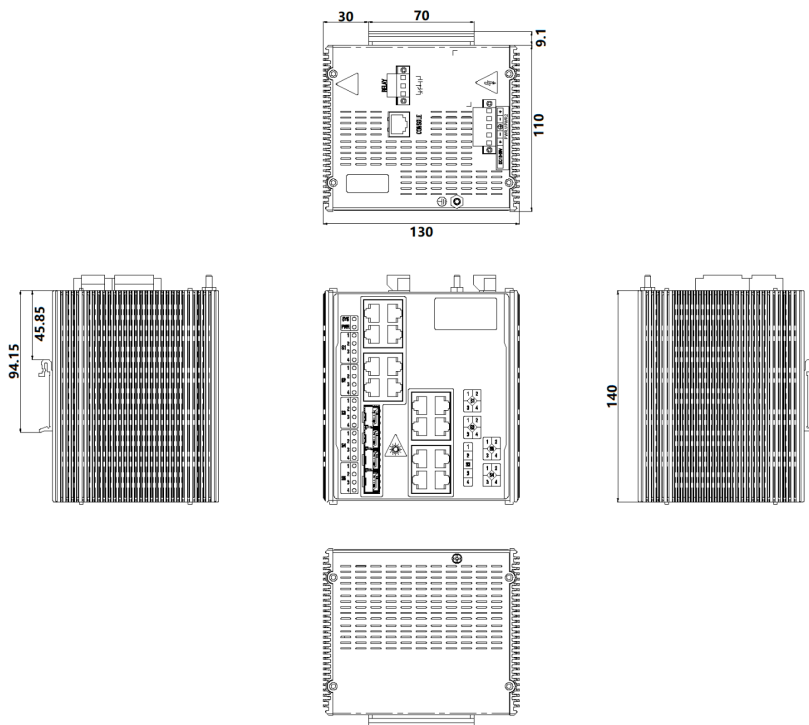

130mm x 140mm x 110mm

Technical Specifications

- IEEE 802.3 CSMA/CD method and physical Layer specifications
- IEEE 802.1p Class of Service
- IEEE 802.1q VLAN tagging
- IEEE 802.1d Spanning Tree Algorithm
- IEEE 802.1w Rapid Spanning Tree
- IEEE 802.1s Multiple Spanning Tree
- IEEE 802.3ac VLAN Tagging
- IEEE 802.1x Authentication
- IEEE 802.3ad Link Aggregation
- IEEE 802.3x Flow Control
- IEEE 802.3 Ethernet
- IEEE 802.3u Fast Ethernet
- IEEE 802.3z Gigabit Ethernet
- IEEE 802.1ab Link Layer Discovery Protocol
- RFC 768 UDP
- RFC 791 IP
- RFC 792 ICMP
- RFC 793 TCP
- RFC 826 ARP
- RFC 854 Telnet Client & Server
- RFC 862 Echo Protocol
- RFC 863 Discard Protocol
- RFC 904 Exterior Gateway Protocol Formal Specification
- RFC 1027 Using ARP to Implement Transparent Subnet Gateways
- RFC 1058 RIP
- RFC 1059, 1119 NTPv1/2
- RFC 1112 IGMP
- RFC 1191 Path MTU Discovery
- RFC 1388 RIP Version 2 Carrying Additional Information
- RFC 1403 BGP OSPF Interaction
- RFC 1519 CIDR (Classless Inter-domain Routing)
- RFC 1587 OSPF NSSA
- RFC 1812 Requirements for IP Version 4 Routers
- RFC 1994 PPP Challenge Handshake Authentication Protocol (CHAP)
- RFC 2068 HTTP
- RFC 213 DHCP Server
- RFC 2138 RADIUS
- RFC 2139 RADIUS Accounting
- RFC 2236 IGMPv2
- RFC 2328 OSPF V2
- RFC 2338 VRRP
- RFC 2370 The OSPF Opaque LSA Option
- RFC 2474 DiffServ Precedence
- RFC 2475 DiffServ Core and Edge Router Functions
- RFC 2597 DiffServ Assured Forwarding
- RFC 2598 DiffServ Expedited Forwarding
- RFC 2644 Directed Broadcasts
- RFC 2865 Remote Authentication Dial User Service (RADIUS)
- RFC 3046 DHCP Relay Agent Information Option
- RFC 3222 Forwarding Information Base (FIB)
- GMRP GARP
- GVRP GARP
- SSH2 Secure Shell 2
- IGMP snooping
- SNMPv3
- RFC 1256 ICMP Router discovery protocol ICMP
- RFC 1267 A Boarder Gateway Protocol 3 (BGP-3)

Advantages and Features

ISM5020D Product specifications			
Project	ISM5020D-P-4GSFP-16GT-24		
Physical Performance			
Dimensions	130mm x 140mm x 110mm		
Enclosure	Fully enclosed seamless metal enclosure		
Weight	1.3 kg	Protection Grade	IP40
Installation	DIN-rail mounting	Cooling Method	Fanless cooling
Fanless cooling	-40 ~ +85°C	Operating Temperature	-40 ~ +85°C
Ambient Humidity	5 ~ 95% (non-condensing)		
Hardware performance			
Backplane Bandwidth	68 Gbps	Transmission mode	Parallel Storage forwarding
RAM	1G	Flash	32M
MAC Table Size	16 K	Packet Buffer Size	4 Mbit
Exchange Rate	148,800 pps/100M ports; 1,488,000 pps/1000M ports		
Software Functions			
Redundancy	ERPS, MRP, RSTP, MSTP, Port Trunking		
Management Mode	Web, serial port, STD-17 MIB-II, STD-58 SMIPv2, STD-59 RMON, STD-62 SNMPv3, SNMPv2c, SNMPv1, RFC2925 Ping MIB		
Time Synchronization	SNTP		
Diagnostic Mode	Indicator light, journal file, relay, RMON, port mirroring, TRAP		
Others	4K VLANs ID, 256 Active VLANs, IPv4/IPv6 multicast, storm control, MC/BC protection, support Jumbo Frame, HTTPS, SSHv2, and SFTP, supports QoS 8 queues		
Certifications	CE, FCC, IEC61850-3		

ISM5020D Product specifications			
Project	ISM5020D-P-4GSFP-16GT-24		
Electromagnetic Characteristics			
EMI	FCC 47 CFR Part 15 Class A EN55022 Class A		
EMS	IEC(EN)61000-4-2, Class 4 IEC(EN)61000-4-3, Class 3 IEC(EN)61000-4-4, Class 3 IEC(EN)61000-4-5, Class 4 IEC(EN)61000-4-6, Class 3 IEC(EN)61000-4-8, Class 5 IEC(EN)61000-4-11, Class 4 IEC(EN)61000-4-12, Class 3		
Mechanical Characteristics			
Shock	IEC60068-2-27	Freefall	IEC60068-2-31
Vibration	IEC60068-2-6		
Power Parameters			
Input Voltage	18-60VDC Redundant dual input		
Overload Current Protection	Supported	Reverse Polarity Protection	Supported
Quality Assurance			
Warranty Period	5 years	MTBF	35 years

Recommended Models

Model	Description
ISM5020D-P-4GSFP-16GT-24	20-port Layer 3 managed Industrial Switch. 16* 10/100/1000Base-T/TX RJ45 Autosense MDI/MDI-X Port + 4 * 100/1000/2500BaseX SFP slots (1000Base-SX, 1000Base-LX, 1000Base-T/TX, 2.5GVase-SX and 2.5GBase-LX modules can plug to SFP Port). Isolated Dual 18-60VDC Power Inputs. 1 management Serial CLI port, 1 Alarm Relay port (250VAC, 2A@250VAC or 125VDC, 2A@30VDC).

About Us

InHand Networks is a leading IoT solutions provider founded in 2001, dedicated to driving digital transformation across industries and empowering customers to unlock their full potential and achieve accelerated growth.

We specialize in delivering industrial-grade connectivity solutions for diverse sectors, such as enterprise networks, industrial and building IoT, digital energy, smart commerce, and mobility. Our comprehensive product portfolio and services cater to various applications worldwide, including smart manufacturing, smart grid, intelligent transportation, smart retail, etc. With a global footprint spanning over 60 countries, we serve customers in China, the United States, France, Germany, the United Kingdom, Italy, and beyond.



3650 Concorde Pkwy, Suite 200
Chantilly, VA 20151, USA
T: +1 (703) 348-2988
E: info@inhandnetworks.com
www.inhandnetworks.com