

Build advanced and highly reliable industrial Ethernet communication system

ISM5X10D-P

Managed Industrial Ethernet Switch



The ISM series of managed industrial Ethernet switches is specifically designed to meet the demands of harsh industrial environments such as power, transportation, and industrial control applications. The rugged casing design and protected circuits among other industrial-grade features perform its remarkable adaption to rough environments. It can reliably operate in extreme temperature conditions, effectively addressing challenges posed by demanding environments.

Furthermore, the ISM5X10D also owns advanced and comprehensive network functionalities, supporting STP/RSTP/MSTP ring redundancy protocols, offering users a flexible choice for constructing intricate industrial Ethernet communication systems. Whether faced with challenging production environments or stringent requirements for reliability and availability in industrial applications, InHand Networks' industrial Ethernet switches can meet your expectations.

Solutions

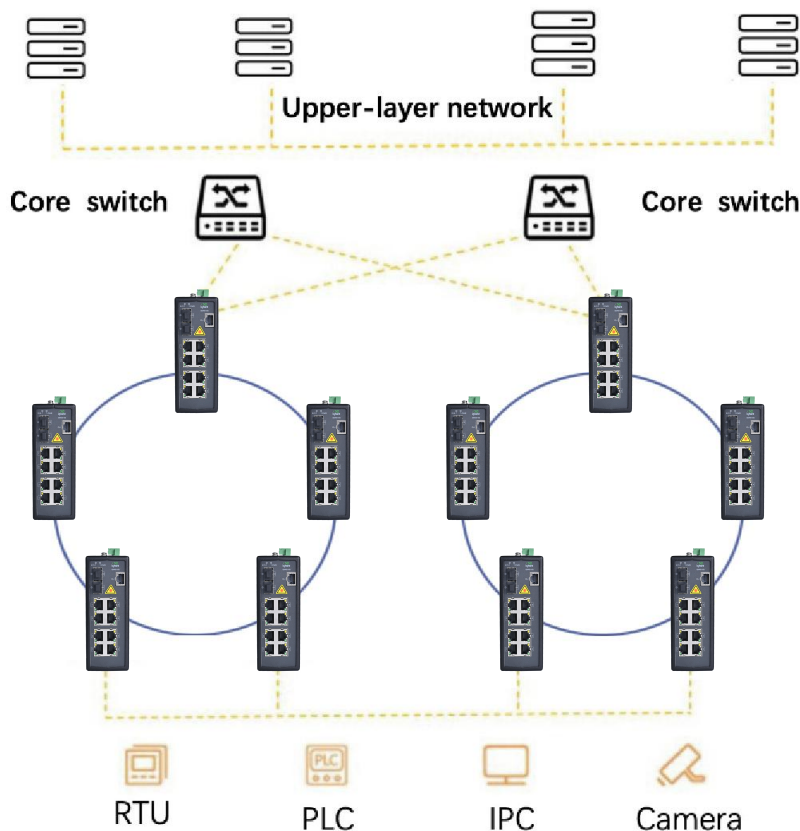

Advantages and Features

- + QoS supported to process critical data in heavy traffic
- + Excellent EMC electromagnetic compatibility and radiation performance.
- + Port-based VLAN, IEEE 802.1Q VLAN, and GVRP to ease network planning
- + Adopting redundant dual input power design
- + Supports IEEE 802.3af/at PSE (Power Sourcing Equipment)
- + Each PoE port provides up to 30W output power

● Build advanced and highly reliable industrial Ethernet communication

ISM Managed Industrial Switch features a rugged metal casing and protective coating, providing pressure resistance and corrosion protection.

The product is fanless, with IP30/IP40 protection, dust and dirt resistance, and supports wide temperature operation.

Industrial-grade redundant power supply design, wide voltage input, ensuring stable communication in harsh industrial environments.

The product's MTBF (Mean Time Between Failures) is over 35 years.

● Efficient and effortless deployment and management

The ISM series supports SNMP for integrated network management with different network management systems.

Supports RMON to enable comprehensive and effective network monitoring and fault prediction, allowing users to quickly and efficiently deploy and manage network.

Features with DIN rail installation, small size, plug-and-play, and quick deployment.

● Robust network security performance

IGMP Snooping.

Intelligent features such as VLAN network segmentation.

Product dimensions(mm)

ISM5X10D Dimensional diagram

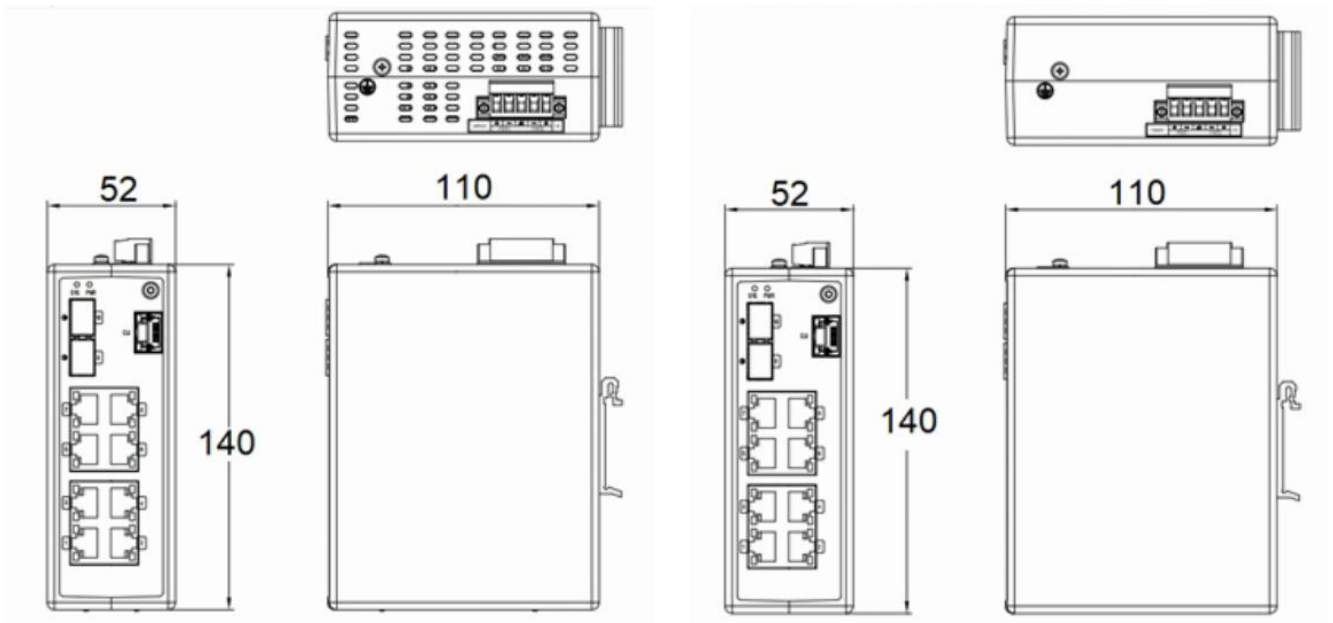

ISM5310D Dimensional diagram

ISM5010D Dimensional diagram

52mm x 140mm x 110mm

Technical Specifications

- IEEE 802.3 CSMA/CD method and physical Layer specifications
- IEEE 802.1p Priority Queuing
- IEEE 802.1q VLAN tagging
- IEEE 802.1d Spanning Tree Algorithm
- IEEE 802.1w Rapid Spanning Tree
- IEEE 802.1s Multiple Spanning Tree
- IEEE 802.3ac VLAN Tagging
- IEEE 802.1x Authentication
- IEEE 802.3ad Link Aggregation
- IEEE 802.3x Flow Control
- IEEE 802.3 Ethernet
- IEEE 802.3u Fast Ethernet
- IEEE 802.3z Gigabit Ethernet
- IEEE 802 Networks
- RFC 768 UDP
- RFC 791 IP
- RFC 792 ICMP
- RFC 793 TCP
- RFC 826 ARP
- RFC 854 Telnet Client & Server
- RFC 862 Echo Protocol
- RFC 863 Discard Protocol
- RFC 867 Daytime Protocol
- RFC 868 Time Protocol
- RFC 1059, 1119 NTPv1/2
- RFC 1191 Path MTU Discovery
- RFC 1403 BGP OSPF Interaction
- RFC 1542 Bootstrap Extensions & DHCP
- RFC 1994 PPP Challenge Handshake Authentication Protocol
- RFC 2068 HTTP
- RFC 213 DHCP Server
- RFC 2138 RADIUS
- RFC 2139 RADIUS Accounting
- RFC 2236 IGMPv2
- RFC 2474 DiffServ Precedence
- RFC 2597 DiffServ Assured Forwarding
- RFC 2598 DiffServ Expedited Forwarding
- RFC 2865 Remote Authentication Dial In User Service (RADIUS)
- RFC 3046 DHCP Relay Agent Information Option
- RFC 3222 Forwarding Information Base (FIB)
- GMRP GARP
- GVRP GARP
- SSH2 Secure Shell 2
- IGMP snooping
- SNMPv3

Product specifications

ISM5X10D Product specifications				ISM5X10D Product specifications			
Project	ISM5X10D-P			Project	ISM5X10D-P		
Physical Performance				Electromagnetic Characteristics			
Dimensions	52mm x 140mm x 110mm			EMI	FCC 47 CFR Part 15 Class A EN55022 Class A		
Enclosure	Fully enclosed seamless metal enclosure			EMS	IEC(EN)61000-4-2, Class 4		
Weight	0.7 kg	Protection Grade	IP40 / IP30		IEC(EN)61000-4-4, Class 4		
Cooling Method	Fanless cooling	Installation	DIN-rail mounting		IEC(EN)61000-4-5, Class 4		
Storage Temperature	-40 ~ +85°C	Operating Temperature	-40 ~ +75°C		IEC(EN)61000-4-11, Class 4		
Ambient Humidity	5 ~ 95% (non-condensing)				IEC(EN)61000-4-12, Class 4		
Hardware performance				Mechanical Characteristics			
Backplane Bandwidth	44 Gbps	Transmission mode	Parallel Storage Forwarding	Shock	IEC60068-2-27	Freefall	IEC60068-2-31
MAC Table Size	8 K	RAM	128 MB	Vibration	IEC60068-2-6		
Packet Buffer Size	1.5 Mbits			Software Functions			
Exchange Rate	148,800 pps/100M ports; 1,488,000 pps/1000M ports			Redundancy	STP, MSTP, RSTP, Port Trunking		
Power Parameters				Management Mode	Browser, Serial Port, STD-17 MIB-II, STD-58 SMiv2, STD-59 RMON, STD-62 SNMPv3, SNMPv2c, SNMPv1		
Input Voltage	18 ~ 60VDC dual redundant input (ISM5010) 48 ~ 57VDC dual redundant input (ISM5310)			Time Synchronization	NTP		
Overload Current Protection	Supported	Reverse Polarity Protection	Supported	Diagnostic Mode	Indicator light, Journal File, RMON, Port Mirroring, TRAP		
Power Consumption	10W (ISM5010)			Certifications			
PoE (ISM5310D)				CE, FCC (ISM5010D / ISM5310D) IEC61850-3 (ISM5310D)			
PoE 10/100/1000BaseT Ports	8 ports						
Maximum Power	15.4W (IEEE 802.3af); 30W (IEEE 802.3at)						
Quality Assurance							
Warranty Period	5 years	MTBF	35 years				

Recommended Models

Model	Description
ISM5010D-P-2GSFP-8GT-24	10-port Layer2 managed Industrial Switch. 2 * 100/1000/2500BaseX SFP Ports (SFP module not included), 8 * 10/100/1000BaseT Ports. 1 Management Serial CLI Port, IP40 Protection Class, Operating Temperature from -40°C to +75°C. Isolated Dual 18-60VDC Power Inputs.
ISM5310D-P-2GSFP-8GT-48	10-port Layer2 managed Industrial Switch. 2 * 100/1000/2500BaseX SFP Ports (SFP module not included), 8 * 802.3af/at PoE 10/100/1000BaseT Ports. 1 Management Serial CLI Port, IP30 Protection Class, Operating Temperature from -40°C to +75°C. Dual 48-57VDC Power Inputs.

About Us

InHand Networks is a leading IoT solutions provider founded in 2001, dedicated to driving digital transformation across industries and empowering customers to unlock their full potential and achieve accelerated growth.

We specialize in delivering industrial-grade connectivity solutions for diverse sectors, such as enterprise networks, industrial and building IoT, digital energy, smart commerce, and mobility. Our comprehensive product portfolio and services cater to various applications worldwide, including smart manufacturing, smart grid, intelligent transportation, smart retail, etc. With a global footprint spanning over 60 countries, we serve customers in China, the United States, France, Germany, the United Kingdom, Italy, and beyond.



3650 Concorde Pkwy, Suite 200
Chantilly, VA 20151, USA
T: +1 (703) 348-2988
E: info@inhandnetworks.com
www.inhandnetworks.com