

Embrace edge computing  
to empower industrial digitization

# IG502 Series Cost-effective Edge Gateway



• Multiple means of Internet access

• Rich interfaces

• Built-in DSA

• Cloud management

InGateway502 (referred to as IG502) is a cost-effective edge gateway launched by Inhand for the industrial Internet of Things. The IG502 is small in size and rich in interfaces for convenient global cellular access. Support users to use Python secondary development, built-in DeviceSupervisor™ Agent service, support hundreds of communication protocols, easy to achieve device data acquisition, processing and cloud, while supporting DeviceLive cloud management, to help enterprises speed up the digital process.

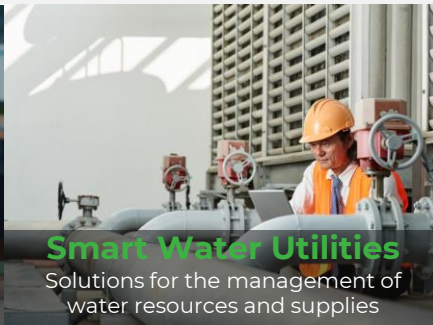
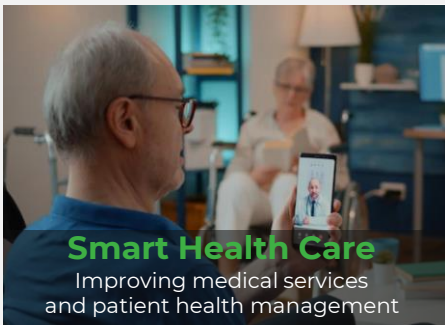

## Solution

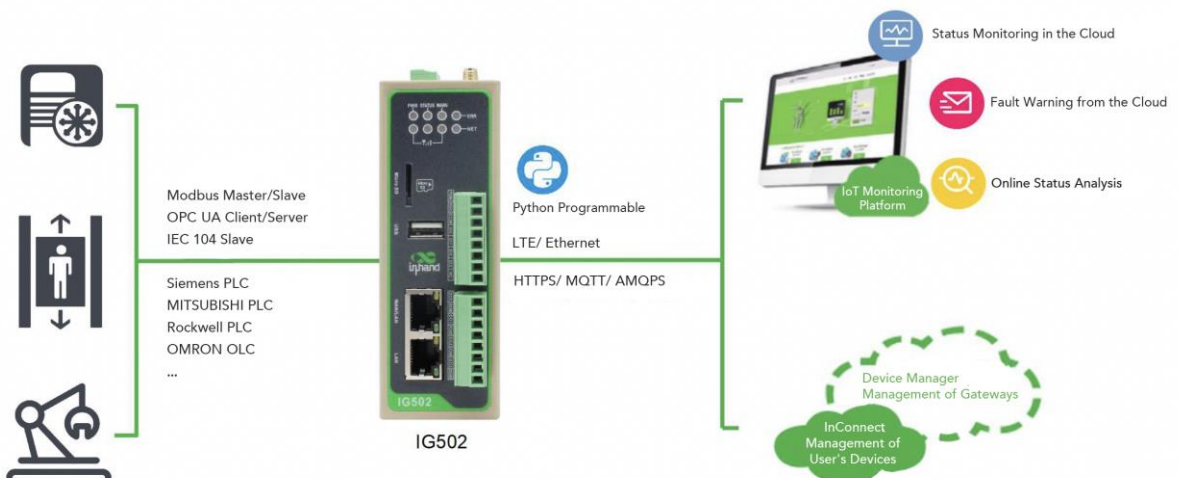

## Feature and Advantage

### Performance and Platform

- High-performance ARM Cortex-A8 processor, 600MHz
- High capacity DDR3 RAM up to 512MB and 8GB eMMC Flash
- Gives the cellular gateway powerful edge computing capability, providing computing resources for data optimization, real-time response, agile connection, and intelligent analysis on edge nodes

### Rich interfaces

- 2x 10/100Mbps ethernet interface
- 1x RS-232/RS-485+1x RS-485
- 1x USB2.0
- 1x MicroSD
- 4x DI+4x DO, optional
- GPS, WIFI and Bluetooth optional

### Stable communication

- 4G/Wi-Fi/FE, etc
- Wired, cellular, Wi-Fi mutual backup, dual SIM failover
- Independent hardware and software watchdog
- Multilevel link detection, communication self-healing



### Industrial-grade, ready for harsh industrial environments

- Operating temperatures up to -20 °C ~ 70 °C, supports +12 ~ 48VDC wide voltage power inputs, protection rating IP30, providing stable and secure network communications for demanding unattended industrial sites

### DeviceSupervisor™ Agent Service

- "Zero code/Low code" easy to achieve data acquisition on the cloud
- Integrate 80+ mainstream data acquisition protocols
- Support data preprocessing
- Integrated data publishing services, public cloud, private cloud, local SCADA and other seamless access

### InHand DeviceLive Cloud Manager

- Supports device remote access
- Supports remote batch management of devices
- Supports DSA remote management
- Supports remote user terminal management



## Dimensions (mm)

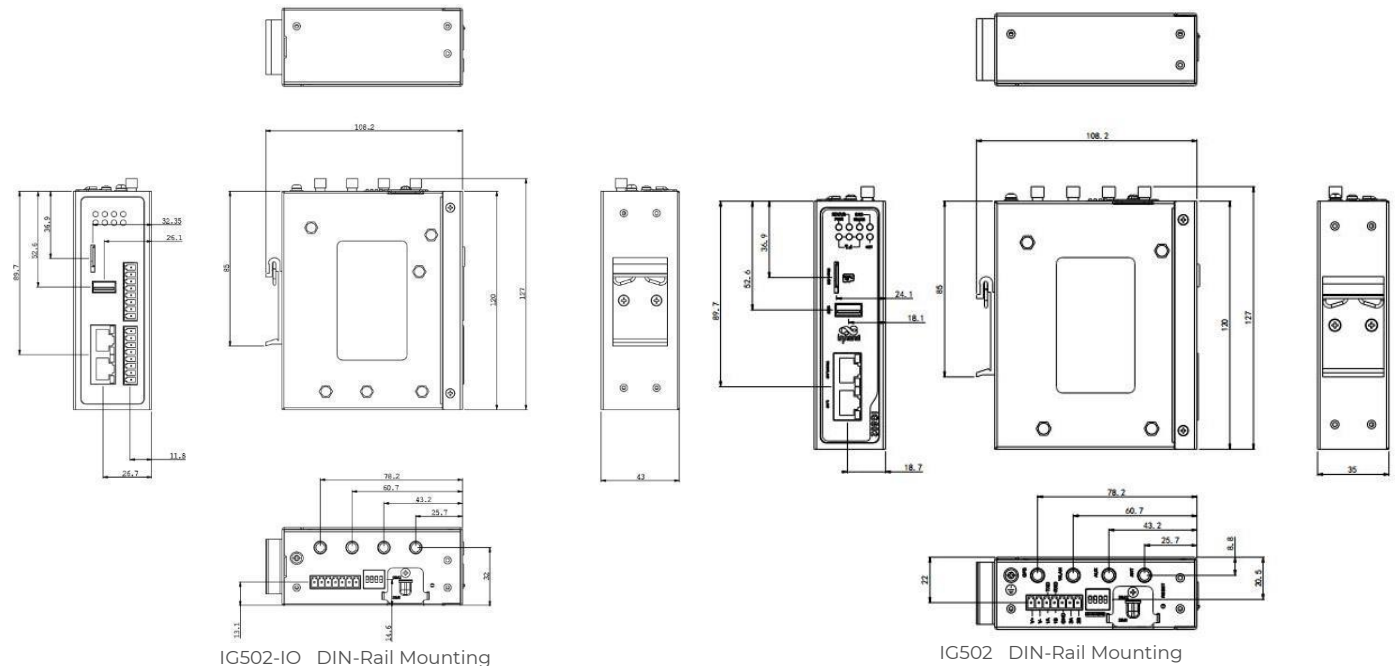

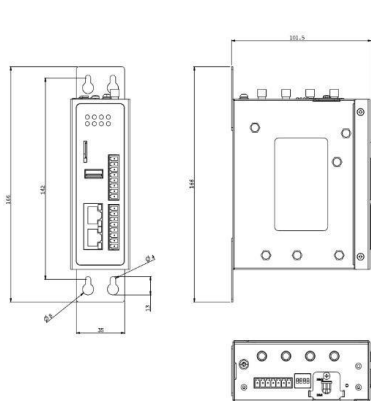

IG502-IO Wall hanging mounting A\*

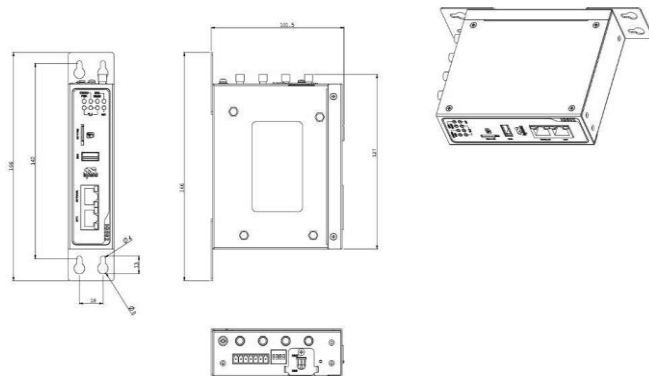

IG502 Wall hanging mounting A\*

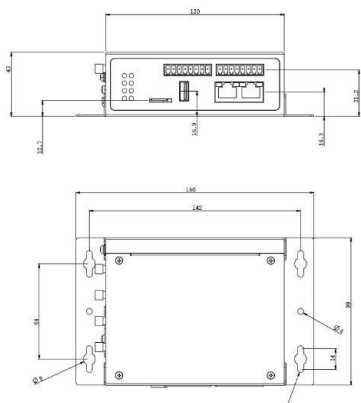

IG502-IO Wall hanging mounting B\*

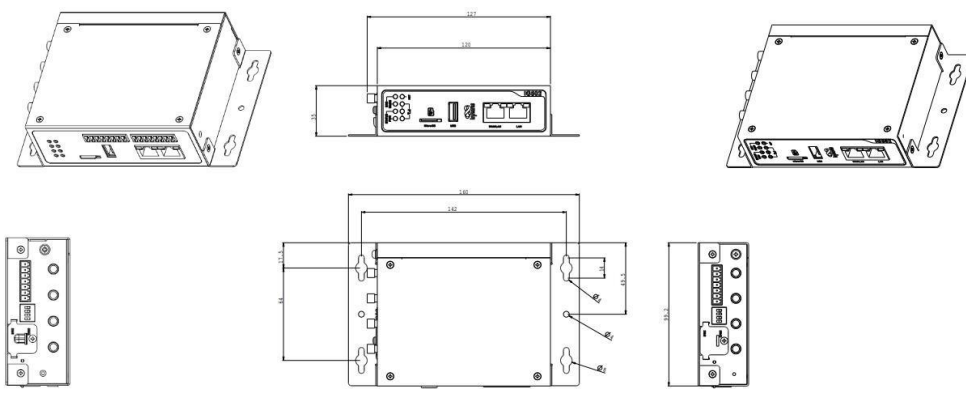

IG502 Wall hanging mounting B\*

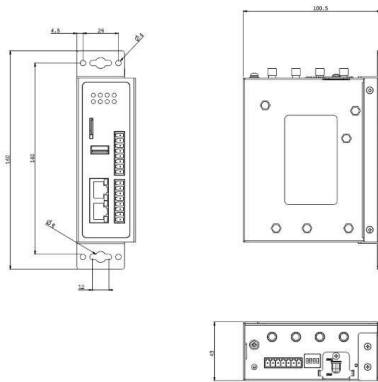

IG502-IO Wall hanging mounting C\*

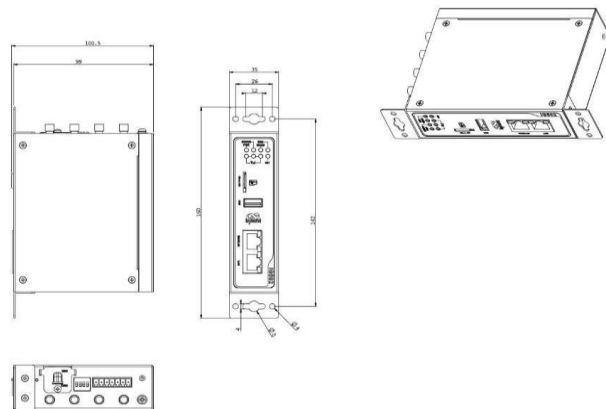

IG502 Wall hanging mounting C\*

\* Wall hanging mounting A's Accessory number: AFIX990001  
 \* Wall hanging mounting B's Accessory number: AFIX000090  
 \* Wall hanging mounting C's Accessory number: AFIX000091

# Product Specifications

Hardware Specifications			
Item	IG502		
Hardware Platform			
CPU	ARM Cortex-A8@600MHz		
RAM	512MB		
FLASH	8GB eMMC		
Interfaces			
Ethernet Port	2 x 10/100Mbps Ethernet port		
Serial Port	RS485 x 1+RS232 x 1/RS485 x 1, industrial terminal block, ordering guide for details		
USB	1 x TypeA, USB 2.0		
SIM Card	Micro SIM x 2		
Antenna Connector	LTE: SMA x 1,Wi-Fi: SMA x 1,GPS: SMA x 1, Note: North America models: 2 x SMA 4G antenna connectors.		
Wi-Fi(Optional)	STA, 802.11/b/g/n, 2.4G		
Bluetooth (Optional)	BLE 4.2		
GPS(Optional)	Satellite location GPS, SMA x 1		
Button	Pinhole reset button x 1		
TF card	MicroSD support, up to 32GB expansion		
Interface extension	Up to 4 x DI+4 x DO		
Others			
RTC	Support (button battery backup)		
Hardware watchdog	Support		
Power			
Power input	12-48V DC		
Power Interface	Industrial terminal block		
Power	250mA@12V		
Mechanical characteristics			
Installation	Panel,Rail	Weight	420g
Dimensions	110x127x35mm	Protection Rating	IP30
Housing	Metal	Cooling	Fanless
Ambient Temperature And Humidity			
Storage Temperature	-40 ~ 85°C	Ambient humidity	5~ 95% (non-condensing)
Operation temperature	-20~ 70 C		
Indicator			
LED	PWR, STATUS, WARN, ERR, Signal Strength (3), LTE		
EMC			
Static	EN61000-4-2,level 3		
Radiation Electric Field	EN61000-4-3,level 3		
Pulsed Electric Field	EN61000-4-4,level 3		
Surge	EN61000-4-5,level 3		
Conducted Disturbance Immunity	EN61000-4-6,level 3		
Shock Wave Resistance	EN61000-4-12,level 3		
Power Frequency Magnetic Field Resistance	EN61000-4-8, horizontal / vertical 400A/m (>level 2)		
Physical Specs			
Shockproof	IEC60068-2-27	Vibration Resistance	IEC60068-2-6
Free Fall	IEC60068-2-32		
Certification			
CE、UKCA、FCC、PTCRB、UL、CID2 (Class1 Division 2)、VerizonWireless、AT&T、IC、RCM、NBTC、ANATEL			

Software Specifications	
Item	IG502
Operating System	
OS	Custom Linux
Internet	
Access authentication	APN、VPDN
Internet access	CHAP/PAP
Network format	5G SA/NSA、LTE Cat1
LAN protocol	ARP、Ethernet
WAN protocol	Static IP、DHCP
Network Protocol	
IP Application	ICMP、DNS、TCP/UDP、TCP/Server、DHCP
IP Routing	Static routing
Security	
Multilevel user	Multi-level management rights
Data security	Firewall
	OpenVPN、IPSec VPN
Reliability	
Link Detection	Sends heartbeat packets to detect, auto redials when disconnected
Dual SIM Failover	Supports dual SIM failover
Embedded Watchdog	Device runs self-detection, auto recovers from malfunctions
Open Platform	
Development Environment	Python
Cloud platform	AWS, Azure, Ali and other cloud platforms
Data Acquisition Protocol(*DSA)	
Industrial Protocol	Modbus RTU Master/Slave, Modbus TCP Master/Slave, EtherNet/IP, ISO on TCP, OPC UA Client/Server, Mitsubishi MC 3C/3E/3C OverTCP, Mitsubishi CPU Port, FINSUDP, HostLink, PPI
Electricity Protocol	DLT645-2007, IEC101/104, DNP3.0
Other Protocol	BACnet, CNC
Network Management	
Configuration	Web, Telnet, SSH
Upgrade	Web, DeviceLive
Log	Support local system logs, remote logs, and important log power-off preservation
Configuration backup	Import and export configuration files
Remote management	DeviceLive or HTTP, HTTPS, SSH, etc.

\*DSA: The DeviceSupervisor Agent (DSA), developed by InHand Networks, is a cutting-edge intelligence software designed to operate on Edge Computer products. It enables clients to quickly implement data collection, processing, protocol conversion, and cloud connectivity through a "zero code/low code" approach. If you need the DSA application on the EdgeComputer product, please contact us to obtain the DSA software package.

## Interface Definition

7 PIN Definition

PIN	Definition	Description
1	V+	Positive electrode
2	V-	Negative electrode
3	TXD or 1A	Serial RS232 send or RS485+
4	RXD or 1B	Serial RS232 receive or RS485-
5	GND	Serial RS232 signal ground
6	A or 2A	Serial RS485+
7	B or 2B	Serial RS485-

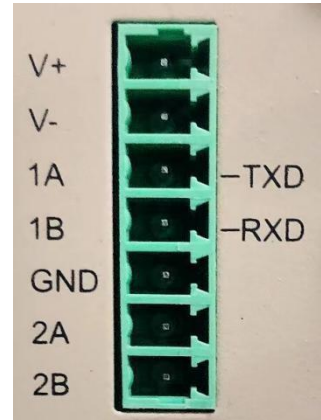

I/O Definition

PIN	Definition	Description	
1	PCOM	Dry contact access point	4x Digital/pulse input DI, 2x Dry contact control port,
2	DGND	Dry contact ground point	1x Common port, 1x Idle,
3	DICOM	Digital input common port	Dry contact status "1": closed
4	DI0	Digital/pulse input port 0	Dry contact status "0": disconnected
5	DI1	Digital/pulse input port 1	Wet contact status "1": +10~+30V/-30~-10VDC
6	DI2	Digital/pulse input port 2	Wet contact status "0": 0~+3V/-3~-0V
7	DI3	Digital/pulse input port 3	Isolation 3000VDC
8	NC	None	Pulse signal counter supported
9	DO0	Digital/pulse output port 0	Supports up to 100Hz pulse signal (32-bit counter + 1-bit overflow mark)
10	DGND	Digital ground	
11	DO1	Digital/pulse output port 1	3x Digital/pulse output DO,
12	DGND	Digital ground	1x Digital output,
13	DO2	Digital/pulse output port 2	4x Digital ground,
14	DGND	Digital ground	Isolation 3000VDC
15	DO3	Digital/pulse output port 3	
16	DGND	Digital ground	

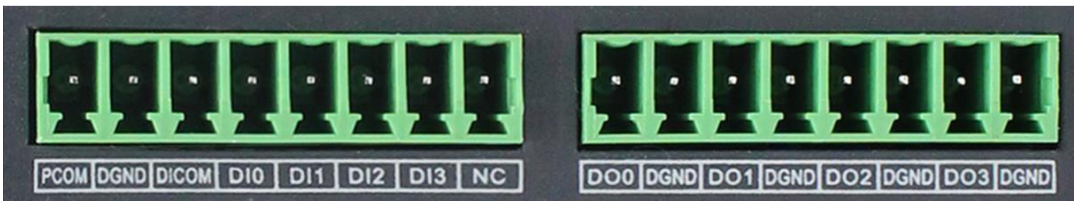

I/O

## Ordering Guide

Model code:IG502-<WMNN>-<W/NA>-<G/NA>						
Model	<WMNN>: Cellular Type & Frequency Band	Ethernet Port	Serial Port	<IO/NA>: I/O	<W/NA>: WLAN&BLE	<G/NA>:GPS
IG502-LQA3	China CAT1 LTE-FDD Band1/3/5/8 LTE-TDD Band34/38/39/40/41 GSM 900/1800MHz	2x 10/100Mbps	RS232 x1 RS485 x1	None	None	None
IG502-LQA3-IO	China CAT1 LTE-FDD Band1/3/5/8 LTE-TDD Band34/38/39/40/41 GSM 900/1800MHz	2x 10/100Mbps	RS232 x1 RS485 x1	4x DI 4x DO	None	None
IG502-LQA3-W-G	China CAT1 LTE-FDD Band1/3/5/8 LTE-TDD Band34/38/39/40/41 GSM 900/1800MHz	2x 10/100Mbps	RS232 x1 RS485 x1	None	YES	YES
IG502-LQA3-IO-W-G	China CAT1 LTE-FDD Band1/3/5/8 LTE-TDD Band34/38/39/40/41 GSM 900/1800MHz	2x 10/100Mbps	RS232 x1 RS485 x1	4x DI 4x DO	YES	YES
IG502-LQA3-D485	China CAT1 LTE-FDD Band1/3/5/8 LTE-TDD Band34/38/39/40/41 GSM 900/1800MHz	2x 10/100Mbps	RS485 x2	None	None	None
IG502-LQA3-D485-IO	China CAT1 LTE-FDD Band1/3/5/8 LTE-TDD Band34/38/39/40/41 GSM 900/1800MHz	2x 10/100Mbps	RS485 x2	4x DI 4x DO	None	None
IG502-LQA3-D485-W-G	China CAT1 LTE-FDD Band1/3/5/8 LTE-TDD Band34/38/39/40/41 GSM 900/1800MHz	2x 10/100Mbps	RS485 x2	None	YES	YES
IG502-LQA3-D485-IO-W-G	China CAT1 LTE-FDD Band1/3/5/8 LTE-TDD Band34/38/39/40/41 GSM 900/1800MHz	2x 10/100Mbps	RS485 x2	4x DI 4x DO	YES	YES
IG502-NRQ1	China 5G NR NSA n41/n78/n79 SA n1/n28/n41/n77/n78/n79 LTE-FDD B1/B3/B5/B8 LTE-TDD B34/B38/B39/B40/B41 WCDMA B1/B5/B8	2x 10/100Mbps	RS232 x1 RS485 x1	None	None	None
IG502-NRQ1-D485	China 5G NR NSA n41/n78/n79 SA n1/n28/n41/n77/n78/n79 LTE-FDD B1/B3/B5/B8 LTE-TDD B34/B38/B39/B40/B41 WCDMA B1/B5/B8	2x 10/100Mbps	RS485 x2	None	None	None
IG502-FQ33	North America CAT1 LTE-FDD Band2/4/5/12/13/25/26 WCDMA Band2/4/5	2x 10/100Mbps	RS232 x1 RS485 x1	None	None	None
IG502-FQ33-IO	North America CAT1 LTE-FDD Band2/4/5/12/13/25/26 WCDMA Band2/4/5	2x 10/100Mbps	RS232 x1 RS485 x1	4x DI 4x DO	None	None
IG502-FQ33-W-G	North America CAT1 LTE-FDD Band2/4/5/12/13/25/26 WCDMA Band2/4/5	2x 10/100Mbps	RS232 x1 RS485 x1	None	YES	YES
IG502-FQ33-IO-W-G	North America CAT1 LTE-FDD Band2/4/5/12/13/25/26 WCDMA Band2/4/5	2x 10/100Mbps	RS232 x1 RS485 x1	4x DI 4x DO	YES	YES
IG502-FQ33-D485-IO-W-G	North America CAT1 LTE-FDD Band2/4/5/12/13/25/26 WCDMA Band2/4/5	2x 10/100Mbps	RS485 x2	4x DI 4x DO	YES	YES
IG502-FF53	EMEA CAT1 LTE-FDD Band1/3/7/8/20/28 GSM/GPRS/EDGE Band3/8	2x 10/100Mbps	RS232 x1 RS485 x1	None	None	None
IG502-FF53-IO	EMEA CAT1 LTE-FDD Band1/3/7/8/20/28 GSM/GPRS/EDGE Band3/8	2x 10/100Mbps	RS232 x1 RS485 x1	4x DI 4x DO	None	None

## Ordering Guide

Model code:IG502-&lt;WMNN&gt;-&lt;W/NA&gt;-&lt;G/NA&gt;

Model	<WMNN>: Cellular Type & Frequency Band	Ethernet Port	Serial Port	<IO/NA>: I/O	<W/NA>: WLAN&BLE	<G/NA>: GPS
IG502-FF53-W-G	EMEA CAT1 LTE-FDD Band1/3/7/8/20/28 GSM/GPRS/EDGE Band3/8	2x 10/100Mbps	RS232 x1 RS485 x1	None	YES	YES
IG502-FF53-IO-W-G	EMEA CAT1 LTE-FDD Band1/3/7/8/20/28 GSM/GPRS/EDGE Band3/8	2x 10/100Mbps	RS232 x1 RS485 x1	4x DI 4x DO	YES	YES
IG502-FF53-D485-IO-W-G	EMEA CAT1 LTE-FDD Band1/3/7/8/20/28 GSM/GPRS/EDGE Band3/8	2x 10/100Mbps	RS485 x2	4x DI 4x DO	YES	YES
IG502-FQ58	EMEA CAT4 LTE-FDD Band1/3/7/8/20/28A WCDMA Band1/8 GSM Band3/8	2x 10/100Mbps	RS232 x1 RS485 x1	None	None	None
IG502-FQ58-IO	EMEA CAT4 LTE-FDD Band1/3/7/8/20/28A WCDMA Band1/8 GSM Band3/8	2x 10/100Mbps	RS232 x1 RS485 x1	4x DI 4x DO	None	None
IG502-FQ58-W-G	EMEA CAT4 LTE-FDD Band1/3/7/8/20/28A WCDMA Band1/8 GSM Band3/8	2x 10/100Mbps	RS232 x1 RS485 x1	None	YES	YES
IG502-FQ58-IO-W-G	EMEA CAT4 LTE-FDD Band1/3/7/8/20/28A WCDMA Band1/8 GSM Band3/8	2x 10/100Mbps	RS232 x1 RS485 x1	4x DI 4x DO	YES	YES
IG502-FQ58-D485-IO-W-G	EMEA CAT4 LTE-FDD Band1/3/7/8/20/28A WCDMA Band1/8 GSM Band3/8	2x 10/100Mbps	RS485 x2	4x DI 4x DO	YES	YES
IG502-FQ58-TH	Thailand CAT4 LTE-FDD Band1/3/7/8/20 WCDMA Band1/8 GSM Band3/8	2x 10/100Mbps	RS232 x1 RS485 x1	None	None	None
IG502-FQ58-IO-TH	Thailand CAT4 LTE-FDD Band1/3/7/8/20 WCDMA Band1/8 GSM Band3/8	2x 10/100Mbps	RS232 x1 RS485 x1	4x DI 4x DO	None	None
IG502-FQ58-W-G-TH	Thailand CAT4 LTE-FDD Band1/3/7/8/20 WCDMA Band1/8 GSM Band3/8	2x 10/100Mbps	RS232 x1 RS485 x1	None	YES	YES
IG502-FQ58-IO-W-G-TH	Thailand CAT4 LTE-FDD Band1/3/7/8/20 WCDMA Band1/8 GSM Band3/8	2x 10/100Mbps	RS232 x1 RS485 x1	4x DI 4x DO	YES	YES
IG502-FQ58-D485-IO-W-G-TH	Thailand CAT4 LTE-FDD Band1/3/7/8/20 WCDMA Band1/8 GSM Band3/8	2x 10/100Mbps	RS485 x2	4x DI 4x DO	YES	YES
IG502-FQ78	Australia & Latin America CAT4 LTE-FDD Band1/2/3/4/5/7/8/28 LTE-TDD B40 UMTS(DC-HSPA+) Band1/2/5/8 EDGE/GPRS/GSM 850/900/1800/1900MHz	2x 10/100Mbps	RS232 x1 RS485 x1	None	None	None
IG502-FQ78-IO	Australia & Latin America CAT4 LTE-FDD Band1/2/3/4/5/7/8/28 LTE-TDD B40 UMTS(DC-HSPA+) Band1/2/5/8 EDGE/GPRS/GSM 850/900/1800/1900MHz	2x 10/100Mbps	RS232 x1 RS485 x1	4x DI 4x DO	None	None
IG502-FQ78-W-G	Australia & Latin America CAT4 LTE-FDD Band1/2/3/4/5/7/8/28 LTE-TDD B40 UMTS(DC-HSPA+) Band1/2/5/8 EDGE/GPRS/GSM 850/900/1800/1900MHz	2x 10/100Mbps	RS232 x1 RS485 x1	None	YES	YES
IG502-FQ78-IO-W-G	Australia & Latin America CAT4 LTE-FDD Band1/2/3/4/5/7/8/28 LTE-TDD B40 UMTS(DC-HSPA+) Band1/2/5/8 EDGE/GPRS/GSM 850/900/1800/1900MHz	2x 10/100Mbps	RS232 x1 RS485 x1	4x DI 4x DO	YES	YES

# Ordering Guide

Model code:IG502-<WMNN>-<W/NA>-<G/NA>						
Model	<WMNN>: Cellular Type & Frequency Band	Ethernet Port	Serial Port	<IO/NA>: I/O	<W/NA>: WLAN&BLE	<G/NA>:GPS
IG502-FQ78-D485-IO-W-G	Australia & Latin America CAT4 LTE-FDD Band1/2/3/4/5/7/8/28 LTE-TDD B40 UMTS(DC-HSPA+) Band1/2/5/8 EDGE/GPRS/GSM 850/900/1800 /1900MHz	2x 10/100Mbps	RS485 x2	4x DI 4x DO	YES	YES
IG502-EN00	Global, no cellular	2x 10/100Mbps	RS232 x1 RS485 x1	None	None	None
IG502-EN00-IO	Global, no cellular	2x 10/100Mbps	RS232 x1 RS485 x1	4x DI 4x DO	None	None
IG502-EN00-W-G	Global, no cellular	2x 10/100Mbps	RS232 x1 RS485 x1	None	YES	YES
IG502-EN00-IO-W-G	Global, no cellular	2x 10/100Mbps	RS232 x1 RS485 x1	4x DI 4x DO	YES	YES
IG502-EN00-D485-IO-W-G	Global, no cellular	2x 10/100Mbps	RS485 x2	4x DI 4x DO	YES	YES

## About Us

InHand Networks is a leading IoT solutions provider founded in 2001, dedicated to driving digital transformation across industries and empowering customers to unlock their full potential and achieve accelerated growth.

We specialize in delivering industrial-grade connectivity solutions for diverse sectors, such as enterprise networks, industrial and building IoT, digital energy, smart commerce, and mobility. Our comprehensive product portfolio and services cater to various applications worldwide, including smart manufacturing, smart grid, intelligent transportation, smart retail, etc. With a global footprint spanning over 60 countries, we serve customers in China, the United States, France, Germany, the United Kingdom, Italy, and beyond.



3650 Concorde Pkwy, Suite 200  
Chantilly, VA 20151, USA  
T: +1 (703) 348-2988  
E: info@inhand.com  
www.inhand.com